

WHELEN®

ENGINEERING COMPANY INC.

51 Windthrop Road
 Chester, Connecticut 06412-0684
 Phone: (860) 526-9504
 Fax: (860) 526-4078
 Internet: www.wheelen.com
 Sales e-mail: autosale@wheelen.com
 Canadian Sales e-mail: canadiansales@wheelen.com
 Customer Service e-mail: custserv@wheelen.com

Installation Guide:
 295SLS*6 Siren Amplifier

DANGER! Sirens produce extremely loud emergency warning tones! Exposure to these tones without proper and adequate hearing protection, could cause ear damage and/or hearing loss! The Occupational Safety & Health Administration (www.osha.gov) provides information necessary to determine safe exposure times in Occupational Noise Exposure Section 1910.95. Until you have determined the safe exposure times for your specific application, operators and anyone else in the immediate vicinity should be required to wear an approved hearing protection device. FAILURE TO FOLLOW THIS RECOMMENDATION COULD CAUSE HEARING LOSS!

Warnings to Installers

Whelen's emergency vehicle warning devices must be properly mounted and wired in order to be effective and safe. Read and follow all of Whelen's written instructions when installing or using this device. Emergency vehicles are often operated under high speed stressful conditions which must be accounted for when installing all emergency warning devices. Controls should be placed within convenient reach of the operator so that they can operate the system without taking their eyes off the roadway. Emergency warning devices can require high electrical voltages and/or currents. Properly protect and use caution around live electrical connections. Grounding or shorting of electrical connections can cause high current arcing, which can cause personal injury and/or vehicle damage, including fire. Many electronic devices used in emergency vehicles can create or be affected by electromagnetic interference. Therefore, after installation of any electronic device it is necessary to test all electronic equipment simultaneously to insure that they operate free of interference from other components within the vehicle. Never power emergency warning equipment from the same circuit or share the same ground circuit with radio communication equipment. All devices should be mounted in accordance with the manufacturer's instructions and securely fastened to vehicle elements of sufficient strength to withstand the forces applied to the device. Driver and/or passenger air bags (SRS) will affect the way equipment should be mounted. This device should be mounted by permanent installation and within the zones specified by the vehicle manufacturer. If any device mounted in the deployment area of an air bag will damage or reduce the effectiveness of the air bag and may damage or dislodge the device. Installer must be sure that this device, its mounting hardware and electrical supply wiring does not interfere with the air bag or the SRS wiring or sensors. Mounting the unit inside the vehicle by a method other than permanent installation is not recommended as unit may become dislodged during swerving, sudden braking or collision. Failure to follow instructions can result in personal injury. Whelen assumes no liability for any loss resulting from the use of this warning device. PROPER INSTALLATION COMBINED WITH OPERATOR TRAINING IN THE PROPER USE OF EMERGENCY WARNING DEVICES IS ESSENTIAL TO INSURE THE SAFETY OF EMERGENCY PERSONNEL AND THE PUBLIC.

Warnings to Users

Whelen's emergency vehicle warning devices are intended to alert other operators and pedestrians to the presence and operation of emergency vehicles and personnel. However, the use of this or any other Whelen emergency warning device does not guarantee that you will have the right-of-way or that other drivers and pedestrians will properly heed an emergency warning signal. Never assume you have the right-of-way. It is your responsibility to proceed safely before entering an intersection, driving against traffic, responding at a high rate of speed, or walking on or around traffic lanes. Emergency vehicle warning devices should be tested on a daily basis to ensure that they operate properly. When in actual use, the operator must ensure that both visual and audible warnings are not blocked by vehicle components (i.e.: open trunks or compartment doors), people, vehicles, or other obstructions. It is the user's responsibility to understand and obey all laws regarding emergency warning devices. The user should be familiar with all applicable laws and regulations prior to the use of any emergency vehicle warning device. Whelen's audible warning devices are designed to project sound in a forward direction away from the vehicle occupants. However, because sustained periodic exposure to loud sounds can cause hearing loss, all audible warning devices should be installed and operated in accordance with the standards established by the National Fire Protection Association.

Safety First

This document provides all the necessary information to allow your Whelen product to be properly and safely installed. Before beginning the installation and/or operation of your new product, the installation technician and operator must read this manual completely. Important information is contained herein that could prevent serious injury or damage.

- Proper installation of this product requires the installer to have a good understanding of automotive electronics, systems and procedures.
- Whelen Engineering requires the use of waterproof butt splices and/or connectors if that connector could be exposed to moisture.
- Failure to use specified installation parts and/or hardware will void the product warranty.
- If mounting this product requires drilling holes, the installer MUST be sure that no vehicle components or other vital parts could be damaged by the drilling process. Check both sides of the mounting surface before drilling begins. Also de-burr the holes and remove any metal shards or remnants. Install grommets into all wire passage holes.
- If this manual states that this product may be mounted with suction cups, magnets, tape or Velcro®, clean the mounting surface with a 50/50 mix of isopropyl alcohol and water and dry thoroughly.
- Do not install this product or route any wires in the deployment area of your air bag. Equipment mounted or located in the air bag deployment area will damage or reduce the effectiveness of the air bag, and become a projectile that could cause serious personal injury or death. Refer to your vehicle owner's manual for the air bag deployment area. The User/Installer assumes full responsibility to determine proper mounting location, based on providing ultimate safety to all passengers inside the vehicle.
- For this product to operate at optimum efficiency, a good electrical connection to chassis ground must be made. The recommended procedure requires the product ground wire to be connected directly to the NEGATIVE (-) battery post (this does not include products that use cigar power cords).
- If this product uses a remote device for activation or control, make sure that this device is located in an area that allows both the vehicle and the device to be operated safely in any driving condition.
- It is recommended that these instructions be stored in a safe place and referred to when performing maintenance and/or reinstallation of this product.
- FAILURE TO FOLLOW THESE SAFETY PRECAUTIONS AND INSTRUCTIONS COULD RESULT IN DAMAGE TO THE PRODUCT OR VEHICLE AND/OR SERIOUS INJURY TO YOU AND YOUR PASSENGERS!



©2008 Whelen Engineering Company Inc.
 Form No. 14130G (01/18/17)

For warranty information regarding this product, visit www.wheelen.com/warranty

Congratulations on selecting the 295SSL-Series Siren. This series offers a unique collection of features designed to allow the user to customize the operation of this siren to suit their individual needs. Features include:

- Programmable Power Distribution Switches
- Power to drive two, 100-Watt Speakers
- Scan-Lock™ Power Distribution & Siren Tone Programming
- Siren Interruption Control
- High and Low Voltage Shutdown
- Program the Siren Tone and the Override Tone of any Rotary switch position
- Enabling or Disabling Auxiliary Siren from the power distribution control switches
- Power distribution control switch type selection (push on push off, momentary, flashing, timed output)
- Auxiliary Input Control
- Hands-Free Operation
- Horn Ring Transfer
- Simulated mechanical Siren Tones
- Speaker Diagnostics
- "Siren in Use" Output
- LED Backlighting
- Harmonically-rich, composite Airhorn Tones
- Title 13-Compliant Profiles
- Non-destructive Short Circuit Protection
- Meets Class A Sound Requirements
- External Back-light Control
- Radio Repeat
- Copy one units configuration to another unit
- Easy reset to default settings
- Power Distribution fuses included

1.0 Mounting:

This siren is designed to be mounted directly onto the dash or other surface through the use of a ball strap mounting bracket. The unit may also be mounted into your vehicle's console (if so equipped).

WARNING: Regardless of the style selected, be sure to observe the air bag warning on the cover of this manual.

WARNING: Mounting this unit will require drilling. It is absolutely necessary to make sure that no other vehicle components could be damaged in the process. Check both sides of the mounting surface before starting. If damage is likely, select a different location.

1.1 Ball Strap Mount:

- Position ball strap in selected mounting location and drill mounting holes, then secure the ball strap to the vehicle.
- Secure the siren to the ball strap as shown. Tighten the acorn nuts firmly.

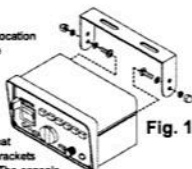

Fig. 1

1.2 Console Mount:

Console manufacturers offer mounting kits that include all the necessary hardware and brackets required to mount this unit into their console. The console mount brackets are secured onto the unit in the same way. Please refer to the manual included with your console.

1.3 Microphone Clip:

A microphone clip is included with this product. **WARNING:** Refer to the Air Bag Warning before installing this clip.

2.0 Wiring:

2.1 Siren Input Connector - RED: Power - BLACK: Ground

WARNING: All customer supplied wires that connect to the positive terminal of the battery must be sized to supply at least 125% of the maximum operating current and FUSED at the battery to carry that load. **DO NOT USE CIRCUIT BREAKERS WITH THIS PRODUCT!**

Current Draw (AMPS)	Wire Gauge / AWG					
	12	10	8	6	4	2
20	15.5	24.5	39	62	98.5	157
30	10.5	16.5	26	41.5	66	104
40	7.5	12.5	19.5	31	49.5	79.5
50	6	10	15.5	25	39.5	63
60	5	8	13	20.5	33	52.5
70	4.5	7	11	17.5	28	45
80	4	6	10	15.5	24.5	39

Distances in inches (in.)

- Splice the 2 RED (Power) wires together, then extend this single RED wire toward the vehicle battery. Splice the 2 BLACK (Ground) wires together and extend this single BLACK wire toward the vehicle battery. To pass the RED and BLACK wires through, you may have to drill a hole in the firewall. Insert a grommet to protect the wires.
- Route the RED and BLACK wires along the factory harness towards the battery and install a fuse block (user supplied) at the end of the RED wire. Remove fuse from fuse block before connecting any wires to battery.
- Connect fuse block wire to POSITIVE terminal on battery. There must not be more than 2 feet of wire between fuse block and battery. The wire between the fuse and battery is "unprotected", do not allow it to chafe and short to ground. Connect the BLACK wire to the factory chassis ground.
-

ORANGE, YELLOW & BROWN - Speaker Wires

- Route the ORANGE, YELLOW and BROWN wires toward vehicle siren speakers, along factory wire harness and through firewall at the same point as the RED and BLACK wires.

- Connect the YELLOW wire to the POSITIVE terminal on SPEAKER #1 and the ORANGE wire to the POSITIVE terminal on SPEAKER #2. **NOTE:** For single speaker installations use the YELLOW wire and cap the ORANGE wire.
- Connect BROWN wire to NEGATIVE connection on speakers #1 & 2.

WHITE & GREY - Horn Relay Wires:

- Route WHITE and GREY wires along factory wire harness and through firewall at the same point as the RED and BLACK wires.
- Route WHITE and GREY wires to vehicle's horn relay. If possible, follow the factory wire harness to this relay.
- Locate the wire that connects the vehicle horn to the horn relay and cut it.
- Connect the WHITE wire to the wire coming from the horn relay.
- Connect the GREY wire to the wire coming from the horn.

Two BLUE wires - Radio Rebroadcast (optional):

The two remaining BLUE wires are used to connect your two-way radio's external speaker for radio rebroadcast (optional connection).

NOTE: If your remote speaker is amplified (speaker has a power amp circuit), radio rebroadcast will not work and should not be used.

- Locate the 2 wires that connect the external speaker to the 2-way radio, cut one of them and splice one of the BLUE wires into this circuit.
- Cut the remaining speaker wire and splice the other BLUE wire into this circuit.

VIOLET - Siren Interruption:

Grounding the VIOLET wire will deactivate the siren. The siren can be programmed to reactivate the tones by 2 different methods (See section 6.8) This wire doesn't affect HORN or MAN push button operations.

2.2 3-Position Input Connector:

Fig. 2
WIRING DIAGRAM

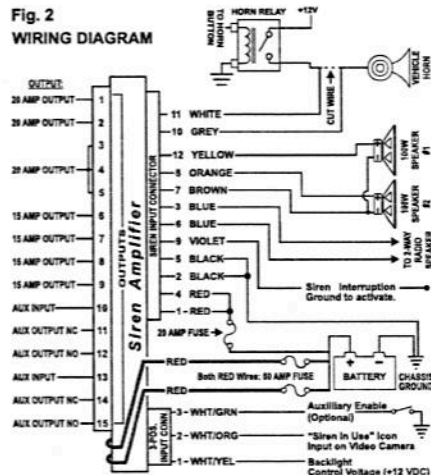

3 Pos. Slide Switch: 3 = OFF 1 Controls Terminal 1
2 Controls Terminal 2 3 Controls Terminals 3, 4 & 5

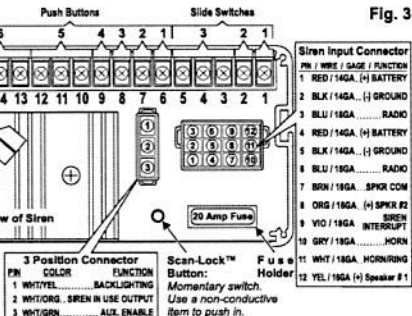
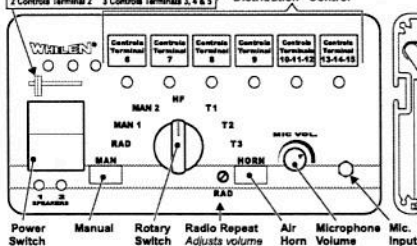

Fig. 3

WHITE/GREEN - Aux Enable:

This wire is activated by switching it to ground (see section 4 for operation).

WHITE/ORANGE - Siren in Use:

Extend the WHITE/ORANGE to the icon input of a video camera. This wire is active positive whenever a siren tone is being produced (200ma max).

WHITE/YELLOW - Backlighting:

Extend the WHITE/YELLOW to the parking light positive voltage. This input is used to drive the backlighting of the siren when the power is off.

2.3 Main Power wires - 10 AWG:

RED - Power / +12VDC:

- Extend the two 10 AWG RED wires along the vehicle factory wire harness towards the battery. Install a 60 AMP fuse block (user supplied) on the ends of each of these wires (see table 1 for correct wire size).

WARNING! Remove the fuse from the fuse block before connecting any wires to the battery.

- Connect each fuse block wire to the positive (+) terminal of the battery. There must not be more than 2 feet of wire between the fuse blocks and the battery. The wire between the fuse and battery is "unprotected," do not allow it to chafe and short to ground.

3.0 Front Panel:

3.1 Power Switch:

This switch has two positions: Up (On) and Down (Off). When this switch is off, siren functions are disabled, however the power distribution switching can be programmed to operate independently of the power switch (default) or activate only when the power switch is on (see section 6.6).

WARNING! If the 295SLS is connected to the vehicle's horn ring circuit, the vehicle horn is disabled when the power switch is ON.

3.2 Rotary Switch

The Rotary Knob controls the siren functions of the 295SLS. There are 7 positions that may be selected (see Section 4.0).

3.3 Volume Knob

The Volume Knob controls the volume of Public Address function. Volume is increased by rotating the knob in a clockwise direction. Rotating the Volume Knob in a counter-clockwise direction decreases the volume produced by these features. The volume knob has no effect on siren tones or radio repeat volume.

3.4 Radio Repeat Volume

Before using the 295SLS, the Radio Repeat output volume must be adjusted to satisfactory operating levels. To adjust this level, a small, flat-blade screwdriver is needed. Locate the Radio Repeat adjustment port (potentiometer) to the right of the Rotary Knob on the face of the control head. Set the volume level of the vehicle's two-way radio to its normal operating volume. Turn the Rotary Knob on the control head to RAD to activate Radio Repeat. Insert the screwdriver in the Radio Repeat adjustment port and turn in a clockwise direction to increase the sound level.

3.5 MAN Button

The Manual button generates a variety of tones, depending on what position the rotary knob is in (see Section 4.0).

3.6 SI TEST® & Diagnostic Indicators

SI TEST is a diagnostic feature of the 295SLS and allows the operator to confirm the proper operation of the siren speakers connected to the unit without activating an audible siren tone. To initiate SI TEST cycle, set the rotary knob to the RAD position. Now press and release the MAN button. As the siren is tested, its diagnostic indicator will turn on steady for about 1.5 seconds if no problems are detected. If the indicator flashes, or does not light at all, a problem with either the siren, speakers, or wiring has been detected. Check the wire connections of the failed speaker and repeat the SI TEST. If the speaker fails to test again, have the siren itself inspected by a qualified technician. **NOTE:** Installed speakers are tested by generating an ultra-high frequency tone through each speaker. Although these tones are inaudible to humans, be sure no one is within 5 feet of the speakers when SI TEST is running.

Diagnostic Indicators:

While this siren is under normal use the diagnostic indicators are used to indicate fault conditions with your siren system. The following table lists the type of fault and the indicator's response. If the indicator is on steady while a tone is in use, this implies that there is no fault with the associated speaker output.

Fault Condition Diagnostic Indicators Response

Under Voltage Speaker LED #2 will be in a DoubleFlash mode (2 quick flashes followed by a longer pause) and siren tones won't operate.

Over Voltage Speaker LED #1 will be in a DoubleFlash mode (2 quick flashes followed by a longer pause) and siren tones will not operate.

Speaker #1 Short Circuit Speaker LED #1 will be in a SingleFlash mode (the LED will be on and off an equal amount of time) and siren tones won't operate.

Speaker #2 Short Circuit Speaker LED #2 will be in a SingleFlash mode (the LED will be on and off an equal amount of time) and siren tones won't operate.

Speaker #1 Open Circuit Speaker LED #1 will be off (having a single speaker system will always cause this condition for the speaker output not in use) all tones will continue to operate.

Speaker #2 Open Circuit Speaker LED #2 will be off (having a single speaker system will always cause this condition for the speaker output not in use) all tones will continue to operate.

3.7 Horn Button

Power up the siren and hold the HORN button on to generate an AIRHORN tone.

3.8 Programmable Power Switches:

The power distribution switches include the slide switch and the six momentary switches. The slide switch having one off position and three active positions combined with the six momentary switches makes a total of nine switch positions. Each of the nine switches there are corresponding outputs on the terminal block in the back of the unit. Each of the nine switches will always activate its own corresponding output, but can be programmed to activate any of the other outputs and/or activate the siren as well (see Section 6.0).

3.9 Microphone:

Whenever the siren is on, activating the microphone (pressing the switch on the side of the mic.) will shut down any other siren functions and enable public address operation regardless of the rotary switch position or any other switch or input.

4.0 Rotary Switch Operations:

This section will outline the operation of the siren in the factory default configuration. Refer to Section 6.3 for information on how to customize the operation of this siren.

4.1 RAD - Radio Repeat: When the rotary knob is in the RAD position, any signal that is received by the vehicle's two-way radio will be simultaneously broadcast over the vehicle's loudspeaker (the unit must be connected to the two-way radio as outlined in this manual).

With the Rotary Switch in this Position:

- Activating the HORN button will produce the AIRHORN tone until released.
- Pressing the MAN button will start SI TEST® as described in Section 3.6.
- Activating the HORN RING input will produce the AIRHORN tone until the HORN RING switch is released.
- Activating the AUX ENABLE input will have no effect.

4.2 MAN 1 - Manual Siren #1: When the rotary switch is in this position the siren is in a standby state where no tones have been activated, but is waiting for another action to be taken by the operator.

With the Rotary Switch in this Position:

- Activating the HORN button will produce the AIRHORN tone until released.
- Pressing the MAN button will produce the AIRHORN tone until the MAN switch is released.
- Activating the HORN RING input will produce the AIRHORN tone until the HORN RING input is released.
- Activating the AUX ENABLE input will produce a repeating WAIL tone until AUX ENABLE input is released.

4.3 MAN 2 - Manual Siren #2: When the rotary switch is in this position the siren is in a standby state. No tones will be activated until another action is taken by the operator.

With the Rotary Switch in this Position:

- Activating the HORN button will produce the AIRHORN tone until released.
- Pressing the MAN switch will produce a WAIL tone. This tone will ramp up to peak frequency and stop when the MAN switch is released.
- Activating the HORN RING input will produce a WAIL tone. This tone will ramp up to peak frequency and stop when the HORN RING input is released.
- Activating AUX ENABLE will produce a repeating WAIL tone until AUX ENABLE input is released.

4.4 HF - Hands-Free Operation - When the rotary knob is in the HF position, the siren functions are placed in a stand-by mode. Siren tones are activated by a single "tap" on the MAN button or on the vehicle's steering wheel horn ring (if the vehicle's horn has been wired to the HORN RING input). The first tap produces a "Wail" tone (a steady rise and fall tone). A second tap produces a "Yelp" tone (a fast rise and fall tone). A third tap produces a "Piercer™" tone (an extremely fast rise and fall tone). The next tap returns the siren to a Wail tone and the cycle repeats itself. Two quick successive taps will stop the siren.

With the Rotary Switch in this Position:

- Activating the HORN button will produce the AIRHORN tone until released.
- Pressing the MAN button will produce the HF cycle.
- Activating the HORN RING input will produce the HF cycle.
- Activating the AUX ENABLE input will start the HF cycle. Releasing the AUX ENABLE will stop the cycle.

4.5 T1 - Tone #1: When the rotary knob is in the T1 position, a steady, rise and fall tone (WAIL) is produced.

With the Rotary Switch in this Position:

- Activating the HORN button will produce the AIRHORN tone until released.
- Pressing the MAN button will change the siren tone to a yelp pattern (a fast rise and fall tone). Pressing the MAN button a second time returns it back to WAIL.
- Activating the HORN RING input will change the siren tone to YELP. Activate the HORN RING input again to return to WAIL.
- Activating the AUX ENABLE input has no effect.

4.6 T2 - Tone #2: When the rotary knob is in the T2 position, a fast, rise and fall tone (YELP) is produced.

With the Rotary Switch in this Position:

- Activating the HORN button will produce the AIRHORN tone until released.

- Pressing the MAN button will produce the PIERCER tone. Pressing the MAN switch a second time returns it back to YELP.
- Activating the HORN RING input will produce the PIERCER tone. Pressing the HORN RING input a second time returns it back to YELP.
- Activating the AUX ENABLE input has no effect.

4.8 T3 - Tone #3: When the rotary knob is in the T3 position, an extremely fast, rise and fall tone is produced.

With the Rotary Switch in this Position:

- Activating the HORN button will produce the AIRHORN tone until released.
- Pressing the MAN button will result in the AIRHORN tone until released.
- Pressing the HORN RING input will result in the AIRHORN tone until the HORN RING input is released.
- Activating the AUX ENABLE will have no effect.

5.0 Terminal Operation

5.1 Terminal Specifications

This siren contains 15 screw terminals located in the upper rear panel of the housing. They are designed to activate components that do not exceed specific current draw. **NOTE: It is important that any components connected to these terminals do not exceed the maximum current rating for that terminal.**

Warning! Total power distribution current is not to exceed 80 AMPS.

Terminal	Max. Load	Fuse
1	20 Amps	F1
2	20 Amps	F2
3, 4 & 5	20 Amps Total: These terminals can't be activated individually	F3
6	15 Amps	F4
7	15 Amps	F5
8	15 Amps	F6
9	15 Amps	F7
11	15 Amps	
12	15 Amps	F8/F8A
14	15 Amps	
15	15 Amps	F9/F9A

(Terminals 11 & 14 are always on unless otherwise noted)

In the factory default configuration terminal outputs of the siren are:

Slide Switch Positions:

- 0 = Terminals OFF
- 1 = Terminal #1 ON
- 2 = Terminals #1 & 2 ON
- 3 = Terminals #1, 2, 3, 4 & 5 ON

Push-Button Switches:

- 4 = Terminal #6 ON
- 5 = Terminal #7 ON
- 6 = Terminal #8 ON
- 7 = Terminal #9 ON
- 8 = Terminal #12 ON / Terminal #11 OFF
- 9 = Terminal #15 ON / Terminal #14 OFF

5.2 Custom Fuse Configurations: Push-Buttons 5 & 6 Functionality

(Fuse Locations / Section 7.0)

Terminals #10 & 13 do not function as output terminals and are not used in the default configuration. By changing the positions of specific fuses, these terminals can be configured to control auxiliary circuits. These auxiliary circuits can not exceed 15 amps each.

Moving Fuse #8 from its default position (F8) to its optional position (F8A) allows push-button 5 to control an auxiliary circuit. Connect Power In from the aux. circuit to Terminal #10 and Load Out to Terminal #11 or 12. Push-button 5 will now open and close this circuit.

Moving Fuse #9 from its default position (F9) to its optional position (F9A) allows push-button 6 to control an auxiliary circuit. Connect Power In from the aux. circuit to Terminal #13 and Load Out to Terminal #14 or 15. Push-button 6 will now open and close this circuit.

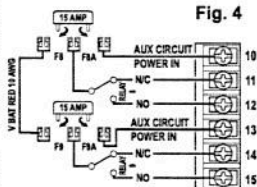

Fig. 4

6.0 Programming the 295SLS*6:

WARNING: Never try to program the siren while it is wired to the vehicle. The siren must be removed from the vehicle before programming. A low level audio device is built into the siren so siren tones can be heard during programming.

6.1 Power Distribution Switch Output Programming:

The lighting control switches include the slide switch and the 6 momentary switches. The slide switch has one off position and 3 active positions, combined with the 6 momentary switches makes a total of 9 active switches. For each of the 9 switches there is 9 corresponding outputs on the terminal block. Each of the 9 switches will always activate its own corresponding output, but can also be configured to activate any other outputs and/or activate the siren.

To Configure a Switch's Outputs:

For programming, connect positive (+) battery and ground only.

1. Put the unit into "switch output" configuration mode.

- Turn the POWER SWITCH OFF.
- Place the SLIDE SWITCH in the OFF position.
- Place the ROTARY SWITCH into the HF position.
- Hold the Scan-Lock™ switch in while turning power on.

To confirm entry into this configuration mode: Speaker #2 Indicator light will flash until a switch is selected to be configured.

2. Select a switch to be configured.

- Press and continue to hold the switch to be configured.
- Press and release the MAN switch.
- Release the switch to be configured.

OR...

- Place the slide switch in the position to be configured.
- Press and release the MAN switch.
- Leave the slide switch in the position to be configured.

The desired switch's indicator light will begin to flash, and any switch's indicator light whose corresponding output is already in the selected switch's configuration will turn on steady. Speaker #1 Indicator light will turn on steady if auxiliary siren control is selected to be activated.

3. Add or Delete Outputs Activated by a Switch:

Press and release one of the six momentary switches to add or delete its corresponding output. This switches indicator light will turn on steady when its corresponding output is selected to be activated.

OR... Press and release the HORN switch to cycle through the SLIDE SWITCH corresponding outputs. Stop when indicator lights equal the desired output pattern.

OR... Press and release the Scan-Lock switch enabling or disabling auxiliary siren control by the selected switch. Speaker #1 Indicator light will turn on steady when auxiliary siren control is selected to be activated.

4. Store the Selected Switch's Output Pattern.

Press the microphones PUSH TO TALK switch. Speaker #2 indicator light will begin to flash, all other indicator lights will turn off and the data will be stored.

To continue configuring other switches, place the SLIDE SWITCH in the off position and start back at step 2. When programming is done, turn power off and then on to activate the changes.

6.2 Power Distribution "Switch Type" Programming:

The 6 momentary lighting control switches located along the top right side of the siren can be configured to operate as 1 of 4 types. The 4 types are: Push On Push Off, Momentary, Flashing Output, and Timed Output (8 seconds).

To Configure a Switch Type, Follow the Steps Below:

1. Put the Unit into "Switch Type" Configuration Mode:

- Turn the POWER switch off.
- Place the SLIDE SWITCH in the off position.
- Place the rotary switch to RAD.
- Hold Scan-Lock switch in while turning the power switch on.

To confirm entry into this mode, speaker #1 indicator light will flash until a switch is selected to be configured.

2. Select a Switch to be Configured:

- Press and continue to hold the switch to be configured.
- Press and release the MAN switch.
- Release the switch to be configured.

The desired switch indicator light will turn on steady. Speaker indicator lights will display a pattern corresponding to the type of switch that is already selected.

3. Choose a Switch Type for the Selected Switch:

- Press and release the HORN switch to cycle through the switch types (table 2).
- Stop when indicator lights equal desired pattern.

Table 2

1	2	LED Speaker Indicator
Off	Off	Push On Push Off
Off	On	Timed Output
On	Off	Momentary
On	On	Flashing Output

4. Store the Selected Switch's Output Pattern.

- Press the microphones PUSH TO TALK switch.
- The Speaker #1 indicator light will begin to flash, all other indicator lights will turn off, and the data will be stored.
- When done programming, turn power off and then on to activate the changes.

6.3 Siren Tone Programming Procedures

With Scan-Lock the tonal operation of the siren can be customized to fit your needs. Scan-Lock is used to change the default siren tones as shown below.

To change the primary tone for rotary switch positions T1, T2, & T3:

Put the rotary switch in the position that you wish to change. Press and release the Scan-Lock switch. Each time the Scan-Lock switch is pressed and released, the next available tone will be broadcast.

When the desired tone is generated, it is automatically saved for that rotary switch position.

TABLE 3 ** This 12 Compliant Tones

Tone List For Rotary Switch Positions T1, T2 & T3		
• TONE OFF	• SIMULATED MECHANICAL	• WOOP
• WAIL*	• PULSED AIRHORN	• WARBLE
• YELP*	• AIRHORN HI/LOW	• B-WAIL
• PIERCER™	• ALTERNATE WAIL	• B-YELP
• V-249*	• ALTERNATE YELP*	• B-HILO
• HI/LOW		

To change the override tone for rotary switch positions T1, T2, & T3:

Put the rotary switch in the position that you wish to change. Press and hold the MAN button on the front panel on the siren. Press and release the Scan-Lock switch. Each time the Scan-Lock switch is pressed and released, the next available tone will be broadcast.

When the desired tone is present, it will automatically be saved as the override tone for that rotary switch position.

TABLE 4 ** This 12 Compliant Tones

Override Tone List For Rotary Switch Positions T1, T2 & T3		
• TONE OFF	• SIMULATED MECHANICAL	• WARBLE
• WAIL*	• PULSED AIRHORN	• AIRHORN
• YELP*	• AIRHORN HI/LOW	• LOW FREQ. HORN
• PIERCER™	• ALTERNATE WAIL*	• B-WAIL
• V-249*	• ALTERNATE YELP*	• B-YELP
• HI/LOW	• WOOP	• B-HILO

When the desired tone is present, it will automatically be saved as the override tone for that rotary switch position. Release the MAN button.

To change one of the tones in the hands free cycle (see Section 4.4):

Put the rotary switch in the HF position.

Using the MAN button on the front panel on the siren, advance to the tone that you wish to change. Press and release the Scan-Lock switch. Each time the Scan-Lock switch is pressed and released, the next available tone will be broadcast.

When the desired tone is generated, it will automatically be saved for that hands-free cycle position.

TABLE 5 ** This 12 Compliant Tones

Tone List For Hands Free Operation:		
• WAIL*	• ALTERNATE WAIL*	
• YELP*	• ALTERNATE YELP*	
• PIERCER™	• WOOP	
• V-249*	• WARBLE	
• HI/LOW	• B-WAIL	
• SIMULATED MECHANICAL	• B-YELP	
• PULSED AIRHORN	• B-HILO	
• AIRHORN HI/LOW		

To change the tone for rotary switch positions MAN1 or MAN2:

Put the rotary switch in the position that you wish to change. Press and hold the MAN button on the front panel on the siren. Press and release the Scan-Lock switch. Each time the Scan-Lock switch is pressed and released, the next available tone will be broadcast.

When the desired tone is generated, it will automatically be saved for that rotary switch position. Release the MAN button.

TABLE 6

Tone List For MAN1 & MAN2 Operation:	
• TONE OFF	
• MAN1AL SIMULATED MECHANICAL COAST-TO-STOP	
• MAN2AL SIMULATED MECHANICAL STOP	
• MAN1AL WAIL COAST-TO-STOP	
• MAN2AL WAIL STOP	
• AIRHORN	
• LOW FREQ. AIRHORN	

To change the override tone for rotary switch position RAD:

Put the rotary switch in the RAD position. Press and hold the MAN button on the front panel on the siren. Press and release the Scan-Lock switch. Each time the Scan-Lock switch is pressed and released, the next available tone will be broadcast.

When the desired tone is generated, it will automatically be saved for that rotary switch position. Release the MAN button.

TABLE 7

Override Tone List For Rotary Switch Position RAD	
• TONE OFF	• LOW FREQUENCY AIRHORN

To change the tone for the HORN button: Put the rotary switch in the MAN2 position. Press and hold the horn button on the front panel of the siren. Press and release the Scan-Lock switch. Each time the Scan-Lock switch is pressed and released, the next available tone will be broadcast. When the desired tone is generated, it is automatically saved for HORN button activation (Table 7).

6.4 Copying a Units Configuration:

If more than one siren needs to be configured to operate in the same manner, it is not necessary to configure each unit separately. Once one unit has been configured to operate as desired, it can now be used as the "primary" unit and its configuration can be copied to another unit that is set up as a "secondary" unit.

To Copy a Configuration to a Second Unit:

1. Connect both units to a common power source (V BAT & Ground). Leave all other wiring not connected.
2. Put the **PRIMARY** unit into "transmit" mode.
 - Turn the POWER switch off.
 - Place the SLIDE SWITCH in the off position.
 - Place the rotary switch into the MAN2 position.
 - Hold Scan-Lock™ switch in while turning power switch on.

To confirm entry to this mode the momentary switch 6 light will turn on.

3. Put the **SECONDARY** unit into "receive" mode:

1. Turn the POWER switch off.
 2. Place the SLIDE SWITCH in the off position.
 3. Place the rotary switch into the MAN1 position.
 4. Hold Scan-Lock™ switch in while turning power switch on.
- To confirm entry to this mode the momentary switch 1 light will go on.
4. Connect the WHITE/ORANGE wire from the **PRIMARY** unit to the WHITE wire of the **SECONDARY** unit. The Speaker #1 indicator will begin to flash on the **SECONDARY** unit to indicate that communications have been established.

5. Press and release the MAN switch on the **PRIMARY** unit to start a transfer. When the indicator for Speaker #2 begins to flash on the **SECONDARY** unit, the transfer is complete.
6. When done programming, turn power off, then on to activate changes.

6.5 Title 13 Operation:

Airhorn will not override primary tones. To put the siren into Title 13 operation mode:

1. Turn the POWER switch OFF.
2. Place the SLIDE SWITCH in the OFF position.
3. Place the ROTARY SWITCH into the RAD position.
4. Hold Scan-Lock™ and HORN switch in while turning power on. Momentary switch 4 light will turn on when a set of Title 13 compliant tones have been programmed for use.

Turn power off, then on to activate changes.

6.6 Power Switch Configuration:

The power distribution switches can be configured to operate independently of the main power switch (default) or operate only with the main power switch in the on position.:

To make the power distribution switches operate with the main power switch.

1. Turn the power switch off.
2. Place the SLIDE SWITCH in the OFF position and the ROTARY switch in the RAD position.
3. Hold Scan-lock™ and HORN switches in while turning POWER switch on. To make the power distribution switches operate independently of the main power switch, restore factory defaults (See Section 6.7).

When the power switch is configured the momentary switch 5 light will go on. Turn power off, then on to activate changes.

6.7 Re-Setting Factory Defaults:

To restore siren tones to the factory defaults:

1. Turn the POWER switch OFF.
2. Place the SLIDE SWITCH in the OFF position.
3. Place the ROTARY SWITCH into the MAN2 position.
4. Hold Scan-Lock™ and HORN switch in while turning power on.

Momentary switch 3 light will turn on when factory defaults are restored. Turn power off, then back on to activate the changes.

To restore lighting control switches to the factory defaults:

1. Turn the POWER switch off.
 2. Place the SLIDE SWITCH in the off position.
 3. Place the rotary switch into the HF position.
 4. Hold Scan-Lock™ and HORN switch in while turning power switch on.
- Momentary switch 2 light will turn on when factory defaults are restored. Turn power off and then on to activate changes.

6.8 Siren Interruption Configuration:

The siren interruption feature can be configured to operate in two modes. **PAUSE:** Grounding the VIOLET wire will deactivate the siren and removing ground from the violet wire will reactivate the siren. **CANCEL:** (Factory default) grounding the VIOLET wire will deactivate the siren however, removing ground from the VIOLET wire will not reactivate the siren. The operator must reset the siren by placing the rotary switch into one of the standby positions (HF, MAN1, MAN2)

To change modes, follow the steps below.

1. Turn the POWER switch off
2. Place the SLIDE SWITCH in the off position
3. Place the ROTARY SWITCH into the RAD position.
4. Hold the Scan-Lock™ and MAN switch in while turning the POWER switch on. Speaker indicators 1 & 2 will display the currently configured mode (see table).
5. Each press and release of the HORN switch will toggle the mode. Use the table to choose the desired mode.
6. When done programming, turn power off and then on to activate changes.

Speaker LEDs	1	2	Interruption Mode
On	Off	Off	Pause Mode
Off	On	On	Cancel Mode

7.0 Accessing the Circuit Board:

To access the circuit board for fuse replacement remove the 4 front screws and slide the chassis out (Fig. 5).

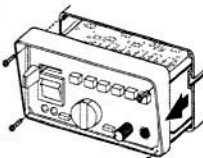

7.1 Specifications

INPUT VOLTAGE	12.8 VDC ±20%
INPUT CURRENT	@15 VDC @ 5.5 OHMS 16 AMPS MAX.
INPUT FUSE	20 AMPS
SPEAKER IMPEDANCE	5.5 OHMS MIN.
OPERATING TEMPERATURE	-30° C. TO +60° C.
STORAGE TEMPERATURE	-40° C. TO +70° C.
HUMIDITY	.99% (NON CONDENSING)
OUTPUT VOLTAGE	@ 15 VDC @ 11 OHMS 34 V RMS MAX.
OUTPUT POWER	@ 15 VDC @ 11 OHMS 105 WATTS MAX.

